

Annual Report

20 24



#BuildingABetterWarren

#BuildingABetterWarren

736 Mahoning Ave.,
Warren, OH 44483

tnpwarren.org



TRUMBULL
NEIGHBORHOOD
PARTNERSHIP

Looking to the Future



Caitlyn Brown
Home Repair Program Coordinator



Terrence Edington
COCS Program Supervisor



Matt Martin
Executive Director



Gillian Costantino
Property Intake and Environmental Programs Coordinator



Jarrod MacCartney
Design & Marketing Coordinator



Madison Schantz
Land Bank Program Associate

“The **vision** of TNP is to transform communities into meaningful places where people invest their time, money, and energy into their homes and neighborhoods; where residents have the capacity to manage day-to-day issues; and where neighbors feel confident about the future of their neighborhood.”



Lisa Ramsey
Deputy Director



Jessica King
Land Bank Special Programs Coordinator

Board of Directors

Don Emerson, President
Jim Brutz, Vice President
Kelly Hutchison, Secretary
Sarah Braun, Treasurer

Andy Barkley
Genevieve Germaniuk
Jill Merolla
Deryck Toles

Mark Waltko
Roy Yancey
Stella Angelo



Sevasti Tripoulas
Community Programs Coordinator



Ashley Yuhasz
Land Bank Administrator



Kevin Stringer
Community Engagement Coordinator



Hailey Zelinsky
BABW Program Coordinator



Lydia Lynch
Food Access Coordinator

“The **mission** of TNP is to empower residents through programming and projects that improve the quality of life in the neighborhoods of Warren and Trumbull County, Ohio.”

Our Partners Who Make It All Possible

Residents of Warren and Trumbull County, 3rd Street Garden, 717 Credit Union, Akron Children’s Hospital of Mahoning Valley, BRITE Energy Innovators, Central State University Extension, Community Foundation of the Mahoning Extension, Community Foundation of the Mahoning Valley, Community Concerned Citizens II, Community Legal Aid, Creating Healthy Communities - Trumbull County Combined Health District, D5 Group, Dave Grohl Alley Committee, Davey Tree Service, Dickey Community Garden, Dominion Energy Charitable Foundation, Eastgate Regional Council of Governments, Family Farm & Home, Farmers National Bank, Federal Home Loan Bank of Cincinnati, First Place Foundation, Foundation for Warren’s Future, Friendship Baptist Church, Free Indeed Urban Farm, Grace A.M.E. Church, Garfield Community Garden, Geauga Trumbull Solid Waste District, Great Ohio Policy Center, Habitat for Humanity of Mahoning Valley, Healthy Community Partnership, Historic Perkins Homestead Neighborhood Association, Huntington National Bank, Inspirational Memorial Garden, Inspiring Minds, John F. Kennedy Catholic School, Kansas State University TAB, Kennedy Family Fund, Kenmore Neighborhood Association, Kent State University, Lady Buggs Farm, Laird Communal Garden, Layla Saves Lives, Legacy Forests, Mercy Health Foundation, NorthMar SERVE, Northwest Neighborhood Association, Ohio Arts Council, Ohio Capital Improvement Corporation, Ohio CDC Association, Ohio Department of Development, Ohio Department of Natural Resources, Ohio EPA, Ohio Housing Finance Agency, Ohio State Extension (Mahoning and

Trumbull County), Paradise Garden Development, Parker Farms, PNC Foundation, Policy Link, Policy Matters, Porter St. Community Garden, Produce Perks Midwest, Remembrance Garden and Park, Rocky Mountain Institute, Roosevelt Area Neighborhood Watch Group, Rotary Club of Warren, Second Baptist Church of Warren, Warren SCOPE, South Eastside Community Association, Tribune Chronicle, TriYouCares, Trumbull Career and Technical Center, Trumbull County Children Services, Trumbull County Combined Health District, Trumbull County Commissioners, Trumbull County Family and Children First Council, Trumbull County Family Court, Trumbull County Farm Bureau, Trumbull County Housing Collaborative, Trumbull County Job and Family Services, Trumbull County Land Reutilization Corporation, Trumbull County Mental Health and Recovery Board, Trumbull County Prosecutor’s Office, Trumbull County Recorder’s Office, Trumbull County SWCD, Trumbull County Senior Levy, Trumbull County Sheriff’s Office, Trumbull County Tourism Bureau, Trumbull County Treasurer Sam Lamancusa and Staff, Trumbull County YMCA, Trumbull County Planning Commission, Trumbull Family Fitness, Trumbull - Mahoning RISE Community Collaborative, Trumbull Memorial Health Foundation, Trumbull Metropolitan Housing Authority, Trumbull 100, Ultium Cells LLC, United Returning Citizens, United Way of Trumbull County, United States Department of Agriculture, United States Department of Housing and Urban Development, United States Environmental Protection Agency, United States Department of Health and Human Services, US EPA, Victory Community Urban Garden, Warren City Council, Warren City Environmental Services, Warren City Mayor Doug Franklin, Warren City Police Department, Warren City Fire Department, Warren City Health District, Warren City Housing Court, Warren City Schools, Warren City Water Department, Warren Community Development, Warren Expressed, Warren Family Mission, Warren Greenhouse Group, Warren Grown, Warren Heritage Center, Warren Municipal Court, Warren - Trumbull CIC, Warren - Trumbull County Public Library, Warren - Trumbull HOME Consortium, Warren - Trumbull NAACP, Western Reserve Land Conservancy, William Swanston Charitable Foundation, Willard Community Space, Youngstown Neighborhood Development Corporation, Youngstown / Warren Regional Chamber and 422 Corridor Project, YSU Regional Economic Development Initiative, YSU GuinFit, Youngstown State University.



Revenue	2024*
Foundations	\$1,105,618.13
Government/Other Grants	\$2,778,833.38
Government/Other Contracts	\$24,000.00
Program Income	\$1,284,751.67
Other Income	\$51,933.48
Total	\$5,245,136.66

Expenses	
Operating Expenses	\$256,671.43
Programs	
TCLRC	\$3,639,436.36
GROW	\$228,121.46
Warren Enriched	\$214,021.88
Building a Better Warren	\$115,946.23
Total	\$4,454,197.36

* 2024 Unaudited



Earth Day Community Clean Up - Ultium Cells



746 Grover in Masury is a developer-renovated homeownership opportunity made possible through TNP and the Trumbull County Land Bank

Community Investment

Home Ownership

\$425,900
Total Property Sales



\$367,710
Private Investment leveraged through buyer renovation

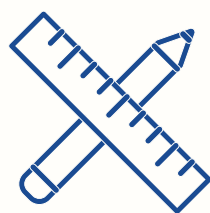

TNP Renovated Properties
6779 West Market \$137,000
3824 Greenmont \$198,000

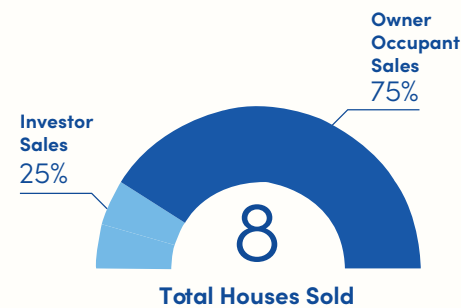

725 Homewood in Warren
\$3,500 purchase price
\$9,000 investment leveraged

746 Grover in Masury
\$10,000 purchase price
\$38,400 investment leveraged

5736 St Rt 82 in Newton Falls
\$10,000 purchase price
\$215,000 investment leveraged

6171 Fairlawn in Hubbard
\$2,500 purchase price
\$64,300 investment leveraged

136 Logan in Warren
\$6,500 purchase price
\$41,000 investment leveraged

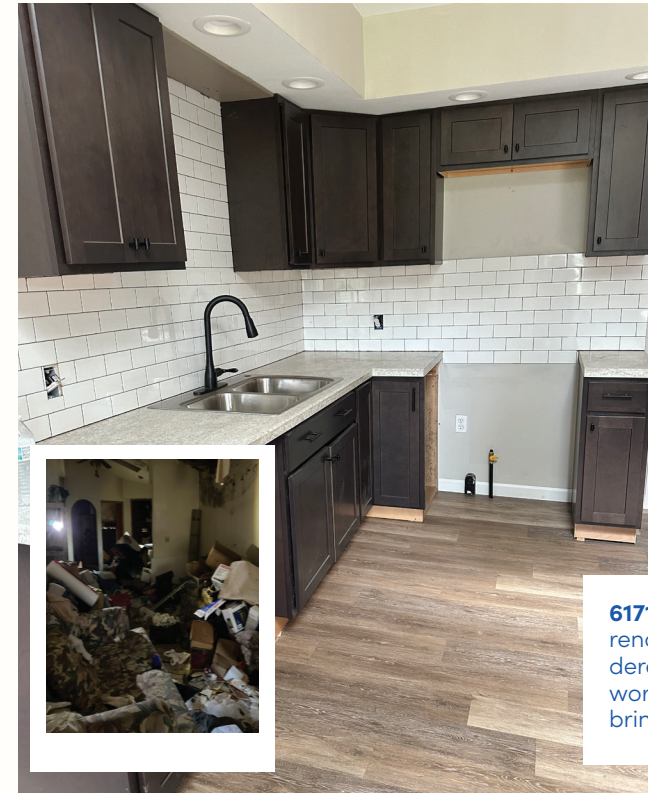

6171 Fairlawn in Hubbard is a prime example of the private renovation investment potential unlocked by the land bank. This derelict vacant property was the recipient of \$64,300 in renovation work by a buyer as a requirement of a \$2,500 purchase price, bringing another abandoned house back to productive use.



3824 Greenmont in Warren was the latest TNP full house renovation which was listed for sale in July and sold in August. This 3 bedroom, 2 bathroom house was in desperate need of renovation but had great potential, it has since been sold to an owner occupant who will live in the home for at least the next 3 years.



Emergency Home Repair

304
Total
Repairs



222
Total
Households
Helped



In 2024, TNP celebrated its sixth year of the Emergency Home Repair Program, marking its busiest and most impactful year yet by assisting **222 households** across Trumbull County. This total reflects a remarkable increase of **104 additional households** compared to the prior year.

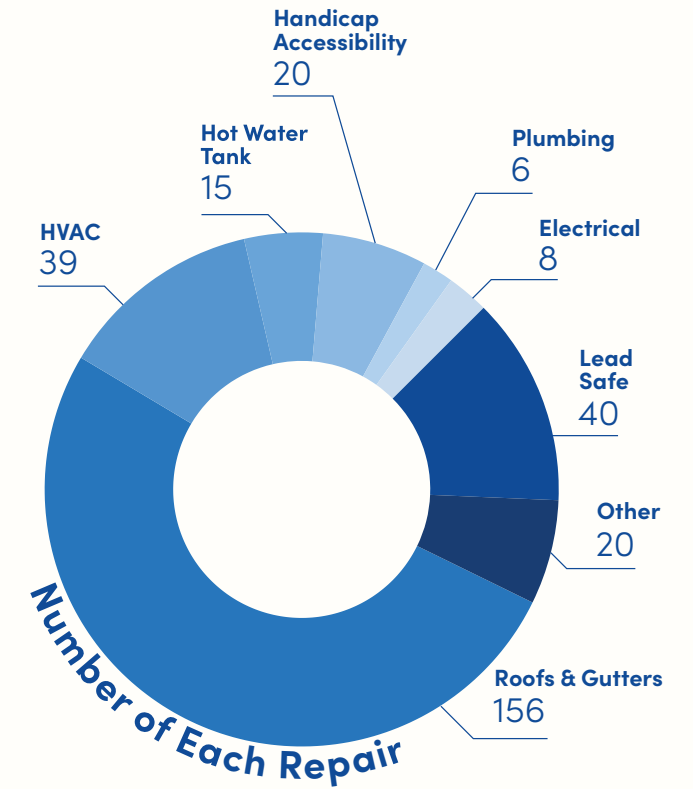

During the year, TNP was awarded **\$1.8 million** in funding to complete lead safe repairs on single family homes, congregate shelters, and childcare settings. Under this program, 40 single family households received assistance, and work was completed at a child care facility and a homeless shelter.

With expanded funding secured for 2025, TNP aims to continue to support households with repairs to ensure families throughout Trumbull County can live safely in their homes while maintaining the program's impactful mission.

All of this success was made possible through diverse funding sources including:

- 🏠 The City of Warren
- 🏠 Trumbull County Commissioners
- 🏠 Trumbull County Senior Levy Services
- 🏠 Federal Home Loan Bank of Cincinnati
- 🏠 Ohio Department of Development Housing Assistance Grant Program
- 🏠 Ohio Department of Development Lead Safe Ohio Program

Repairs Offered Include:

- 🏠 Roof + Gutter Replacements / Repairs
- 🏠 Furnace Replacements / Repairs
- 🏠 Hot Water Tank Replacements / Repairs
- 🏠 Hot Water Tank Replacements / Repairs
- 🏠 Electrical + Plumbing Issue Resolutions
- 🏠 Essential Accessibility Modifications
- 🏠 Lead Safe Houses

Demolition

Completed in 2024

54
Residential
Demolitions

04
Commercial
Demolitions



1,376
Total Demolitions
to Date

Returning Derelict Vacant Property to Productive Use and Creating Home Ownership

The mission of the Trumbull County Land Bank is to return land and vacant abandoned properties to productive use, reduce blight, increase property values, support community land-use goals, and improve the quality of life for all county residents.

TNP and the Land Bank have diligently worked to build wealth in neighborhoods through the acquisition and disposition of properties, which buyers invest their time and resources in to create homeownership opportunities and equity in their property. Started in 2010, the Land Bank has continued to build its programming and impact throughout Trumbull County's neighborhoods. Since its inception, the Land Bank has demolished over **1,300** properties, renovated **500** and facilitated the sale of over **2,100** vacant lots to adjacent property owners, all to create healthier neighborhoods through the remediation of blight and access to homeownership opportunities.

The Land Bank recieved **\$6.3M** through the Ohio Department of Development Building Demolition and Site Revitalization Program grant to perform demolitions on **168 properties** in November.



The U.S. EPA-funded cleanup at the Former Diversified Resources property in Champion is underway, currently in the waste characterization phase. The project will remove thousands of contaminated drums and supersacks, eliminating environmental hazards and preparing the site for productive use. Nearly one million dollars in grant funding has been secured for this effort.



Brownfields

The Trumbull County Land Bank applied for a Brownfield Remediation Grant through the Ohio Department of Development (ODOD) to perform various brownfield remediation tasks including two environmental cleanups and two Phase II site assessments across 4 locations **totaling \$2.3 million.**

A total of **24 Brownfield projects** are currently underway, many of which involve Phase I and Phase II site assessments funded through the Ohio EPA's Targeted Brownfield Assessment Program. This program enables environmental assessments to be conducted at no cost to property owners or requesters, provided they are not responsible for the contamination. These assessments play a crucial role in advancing efforts to clean up abandoned industrial sites and support community revitalization throughout the county.

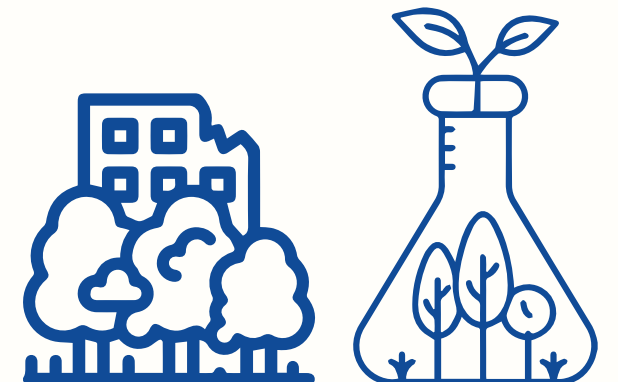

Vacant Land Reuse

2,145
Vacant Lots Sold to Date

172
Side Lot Sales

26
Dead Trees Removed

10
Commercial Vacant Lot Sales



Highlights

The Remembrance Garden Park represents the reclamation of a once vacant lot by Farrah Jones (pictured) and the South East Side Community Association. The project was funded in part through a portion of the city of Warren's American Rescue Plan Act allocation, with TNP providing fiscal sponsorship and technical support.



43
Side Lot Incentive Cards Given Out

02
Greening Installation on Post Demo Lots (vinyl fencing & raised beds)

Side Lot Incentive Program

Walter Allen

Mr. Allen currently has a large greenhouse on one of his lots on the Southwest side of Warren. He hopes to use his gift card to start to expand and add another greenhouse to teach the children in the neighborhood about producing their own food and bringing community

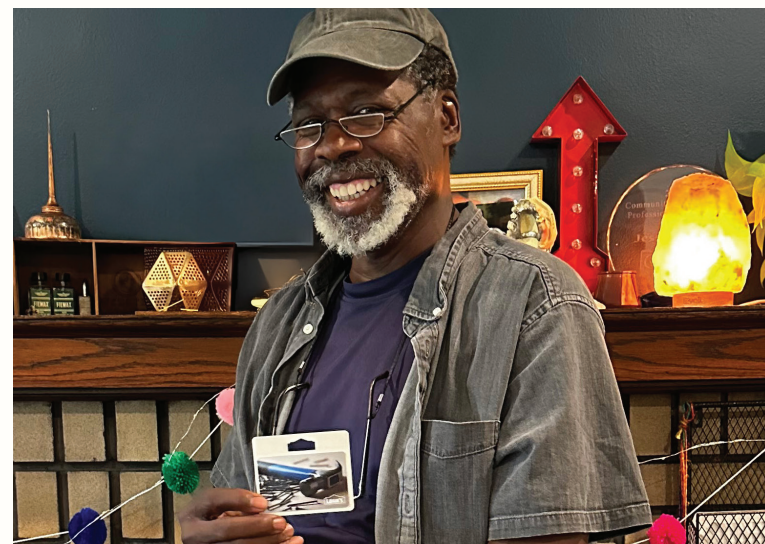

Side Lot Incentive Program

Lisa Killen

Ms. Killen plans to use her gift for new landscaping and a garden on her new side lot on Warren's Southeast side.



Mahoning Valley Tree Corps

Over the next five years, TNP will partner with YNDC and Youngstown CityScape to plant 5,500 shade trees across Youngstown and Warren.

In its first planting season of the grant, TNP was able to plant 97 shade trees across the city of Warren on vacant lots and in the tree lawn. TNP staff canvassed neighborhoods and engaged with residents on the value of trees and beautifying their street. Residents are able to request a tree in their tree lawn, and TNP will plant and maintain the trees during the grant cycle.

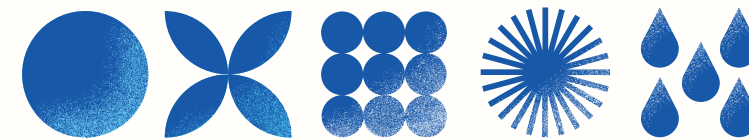

19
Pre-Demolition Properties Salvaged Reducing Waste Taken to Landfills

49
Board-ups Completed on Blighted Properties

8,307
Individual Cuts on Vacant Properties

97
Shade Trees Planted

Building a Better Warren

Trumbull Neighborhood Partnership's Building a Better Warren (BABW) program connects the need for resident-driven community revitalization with job creation, putting residents to work in full-time and year-round jobs doing the work of blight remediation. The program offers residents training and employment in renovation, deconstruction, landscape installation, and vacant property maintenance in order to stabilize the cities' vacant housing stock, mitigate the impacts of blight, and create home ownership opportunities. In 2024, BABW participants assisted in the Mahoning Valley Tree Corps effort.



6th Ward Home Security Program

The 6th Ward Home Security Program is a proactive initiative designed to improve safety and security for community members. The program offers residents the opportunity to make security upgrades to their homes through entry door replacements, the installation of storm doors, and enhancements to front porch lighting. \$50,000 was allocated to TNP from American Rescue Plan funds from 6th Ward Councilwoman Honeya Price to initiate the project.

To date, the program has successfully served 16 properties, resulting in the installation of 24 exterior doors, 26 security doors, and 14 solar lights. By addressing these critical areas, the program not only aims to deter potential threats but also to elevate the aesthetic appeal of the neighborhood.

This initiative seeks to foster a greater sense of security among residents, reinforcing community bonds and encouraging a collective commitment to creating a safe living environment. Open to all 6th Ward residents, whether homeowners or renters, the program represents a significant investment in the well-being and tranquility of the community.

\$50,000
Allocation

\$3,125
Average Cost
Per Home

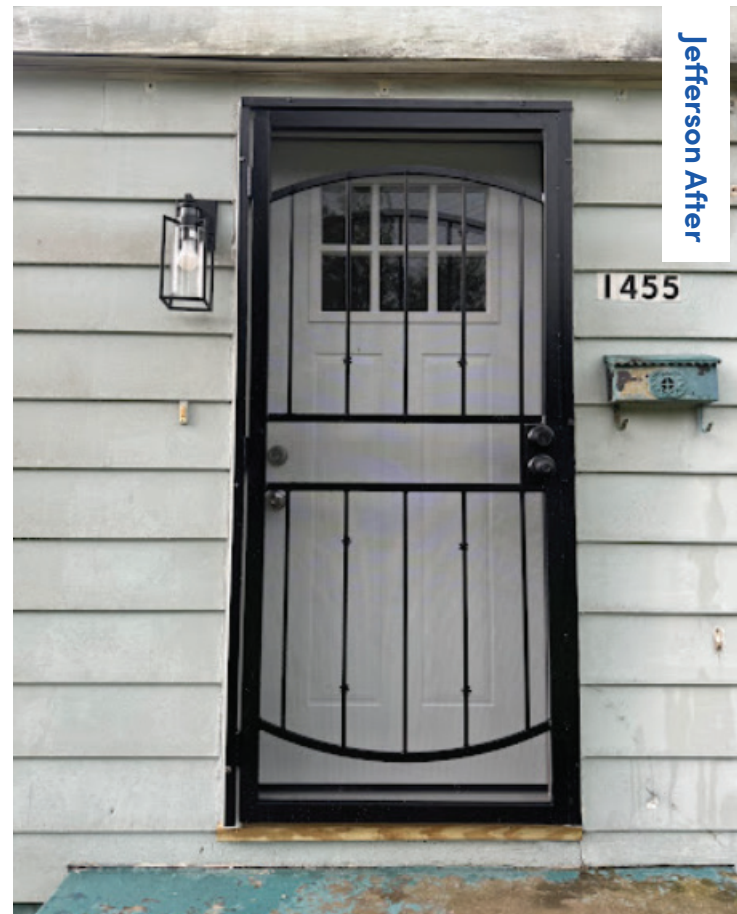
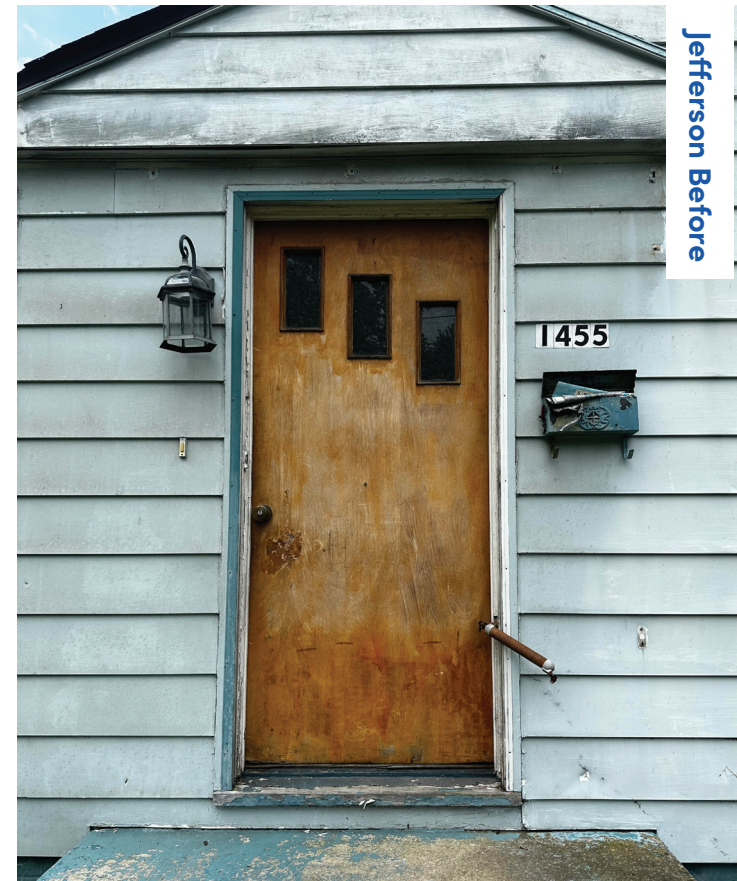
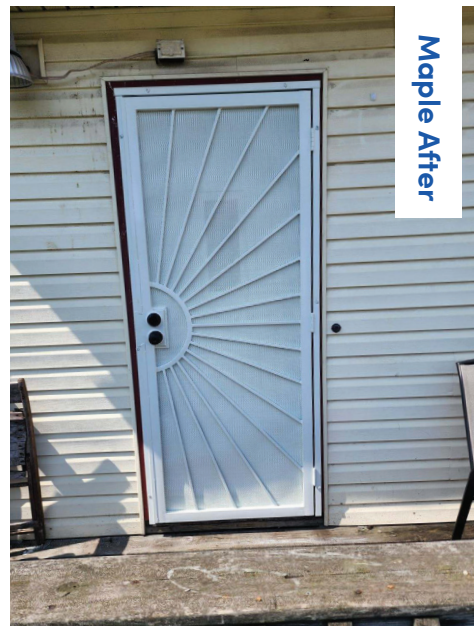
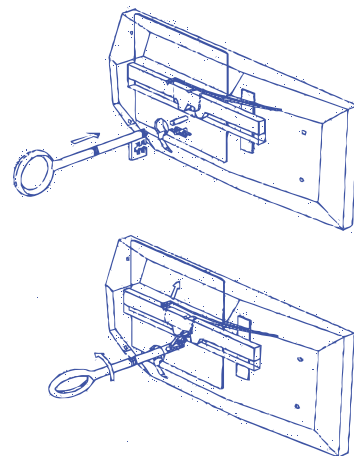

26
Security
Doors



24
Exterior
Doors



16
Properties
Served

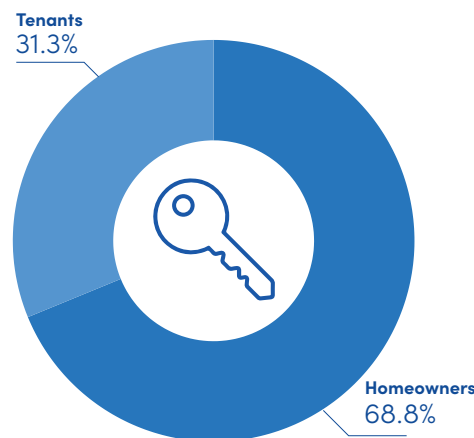
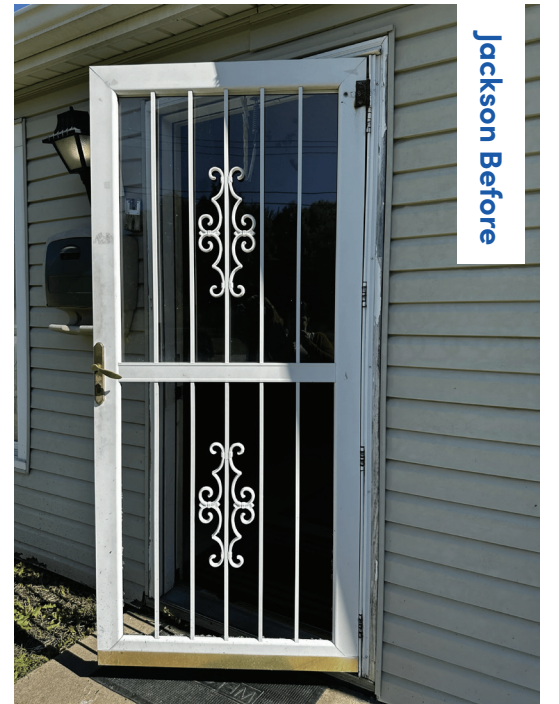

Event Participation

Trumbull Neighborhood Partnership participates in a wide variety of events throughout the community. This is done in support of the programs operated by TNP as well as in support of other community organizations with values aligned to those of Trumbull Neighborhood Partnership. The goal is to work collaboratively in order to make a greater positive impact. Pop Up Markets, School Events and Community celebrations are some examples of the events TNP has attended in order to show support for local agencies and organizations.

Warren City Schools District Kick Off

Youngstown Housing Task Force Day of Action

2nd Annual Celebration of Youth Event @ Grace AME

Grill, Chill, Connect Event @ Warren Family Mission

Red and White Supermarket Event

5h Annual Senior Expo @ Metroplex in Liberty

Youth Empowerment Day Voter Registration & Canvassing Event

Warren Farmers Market Pop Ups

Non-Profit Night at Hiram College

Trunk or Treat @ Jefferson PK-8 School

Steering Clear Warren @ Packard Shelter House

Ultium Cells Health and Wellness Event

Community Thanksgiving Gathering @ New Vision Christian Church

Social Action Sunday @ Second Baptist Church

Tangled Titles Presentation @ Second Baptist Church

Hometown Holiday Event @ Raymond John Wean Foundation

Trumbull O.N.E. Community Christmas Food Drive/Dinner



Affiliation / Representation

In addition to the many longtime relationships with entities like the City of Warren, Trumbull County Commissioners, Warren City Schools and many Neighborhood Associations, TNP is working to grow working rapport with the Faith Based Community and Community Service Agencies. TNP is also participating on several local boards, like Family and Children First Council and the Trumbull County Housing Collaborative in an effort to address the intersectionality of the issues facing the Community.

Trumbull County Mental Health & Recovery Board

Trumbull Memorial Health Foundation

MyPath Mahoning Valley

Healthy Community Partnership

Trumbull County Housing Collaborative

Family and Children First Council

Americorps Seniors

Trumbull-Mahoning Rise Collaborative



Tangled Titles

Trumbull Neighborhood Partnership partnered with Community Legal Aid and Second Baptist Church on **Tangled Titles**, which occur when the title to property is not in the name of the person who should have current legal ownership of a home or other real estate. A presentation was held at Second Baptist to offer solutions to residents.

Community Engagement



Commercial Investment

Franky's Pizza & Deli

The new Franky's Pizza in Warren's Garden District stands as a testament to the transformative impact the Trumbull County Land Bank can help unlock in revitalizing vacant space. Once an abandoned and blighted property, the former Warren Tile and Floor building on Scott Street NE was acquired and held by the Land Bank in 2016. It was later purchased and revitalized in 2024 by the ownership entity from Cockeye BBQ and Cockeye Creamery, turning a derelict property into a community asset.

The renovation is outstanding and the food is even better. Franky's Pizza not only brings an already beloved local dining option to the area but also creates jobs, stimulates economic growth, and contributes to Warren's revitalization.

Braceville African American Heritage Museum

1250 Cedar in Braceville Township was slated for demolition when Ted Toles, Gwen Shavers, and Terrance Shavers (L to R below) approached the Land Bank with the idea of creating an African American heritage museum. They launched the Braceville Community Foundation, received their 501c3 and applied for several grants in order to get the funding for their project. After receiving \$250,000 from the Trumbull County Commissioners ARP funding and the house from the Land Bank, the Braceville African American Heritage Museum has come to fruition. The 1,132 sq. ft. house has been fully renovated and ready to welcome guests from all over Trumbull County to learn about Braceville's rich history.



Warren Farmers Market

05 Local Food Producers
2,428 Shoppers Serviced in 2024
10 Non-profits Attended our Market

Since 2013, the Warren Farmers Market has been a lively community hub highlighting local agriculture and encouraging healthy lifestyles. Situated in the heart of Warren, Ohio, the market features a wide variety of fresh produce, locally raised meats, handcrafted items, and homemade treats.

\$1,522 in Sales for Produce Perks
Total Sales for 2024
\$18,633



“Providing healthy food access to the residents of the City of Warren. 8 non-profit organizations participated in sharing their mission.”



TNP and the Trumbull County Land Bank reclaimed another blighted space, transforming the vacant lot left behind by the demolition of a derelict commercial building at 347 North Park in Warren into the “North Park Commons”, a passive greenspace that is now home to the Warren Farmers Market



9 Years of the Market
Totalled \$248,959 Sales

WFM connected 2,428 consumers with 5 local food producers, fostering a more self-reliant and resilient food network while promoting access to healthy, fresh food and supporting the local economy. WFM also advocated for affordable food access by promoting and implementing three key programs, WIC TANF and Produce Perks, to help make fresh produce more accessible. WFM increased participation in its exercise programs - yoga and walking club. These programs saw weekly participation rise to an average of 10 individuals up from 6 in 2023.

Nutrition Programs

300 WIC Coupon Books Distributed	100 TANF Coupon Booklets Distributed
Totalling \$1,800 in \$5 Coupons	Each Valued at \$140

SFMNP New App Program and QR Code Card Seniors Received \$50	Sales Exceeded \$1,200
--	-------------------------------

POP Kids Club / WFM



The Power of Produce Kids Club allows children to try new fruits and vegetables at the market weekly. Kids get to try a new recipe and participate in activities related to produce. They can also try the Two Bite Challenge, in which they try two bites of the featured fruit or vegetable and receive a \$2 coupon for produce at the market.



\$218
POP Kids Sales

147
Kids Attended in Total

14
Average Kids Participating Weekly

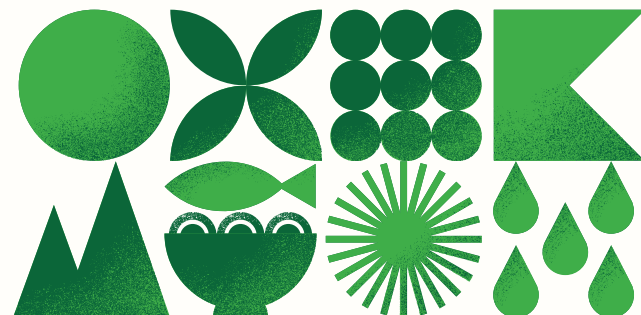

GROW & Community Clean-ups

42
Tires Collected



178
Pairs of Gloves



46
Hours of Volunteer Service



252
Garbage Bags Distributed

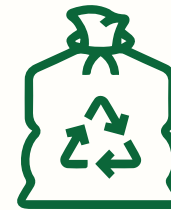

140
Bags Collected



105
Volunteers



21
Miles of the City Reached



39
Pickers

Events & Outreach

Beginning Farmer Training Program Information Session with Central State University Extension // Yoga in the Parks with Kimberly L. Ford at Woman's Park // Vaping and Tobacco Cessation with Trumbull County Combined Health District // Walking Club @ WFM // Cooking without a Recipe with CSU Extension // Zumba Fitness Classes with Tamara Cooper // Cooking on a Budget Class with CSU Extension // Kids' Cooking Classes at 21st Century Program

347
Total Attendance at Health and Wellness Classes

44
Classes Offered in 2024



10

Community Garden Leaders were awarded pre- and post-season \$100 grants to support soil amendments, fertilizers, tools, and ground improvements.



Safe Streets Demo: North Park Avenue

Partners: TCCHD's Creating Healthy Communities, Eastgate Council of Governments, GuinFuit, and Healthy Community Partnership

Residents, businesses, and city officials came together to turn a section of N Park Ave. from 4 lanes, to 2 lanes with a temporary outside bike lane. A creative crosswalk was installed for the day with designs by David Wheeler.

GROW / Community Gardens

Leaders transformed the gardens into therapeutic spaces where residents learned about urban and regenerative agriculture while strengthening their connection to nature.



The community gardens supplied healthy food and highlighted the importance of community relationships and sustainable practices.



The number of community gardens grew from **13 to 17**

05

New green spaces consisted of produce gardens and therapeutic tiny parks created by neighborhood leaders

1,129 plants and

750

seed packets were distributed to **enhance** gardening efforts.

Surplus donated to neighborhood pantry stands, schools, and churches

09 Tilling Support for Gardens



Three new community gardens were equipped with picnic tables, fostering spaces for connection and relaxation.



Red and White Supermarket

1104 W. Market St. in Warren



Red & White Supermarket Celebration

A celebration was hosted at Red & White in August 2024, with over 60 residents coming out to see the store's fresh produce offerings. The event also featured a cooking demonstration by Mercy Health, and locally grown produce from CSU's Beginning Farmer Training students.



There are now 4 locally owned convenience stores that offer fresh produce and other healthy food options consistently throughout the Warren-Trumbull County area. Among the store owners is a shared commitment to improving food security in Warren and changing the narrative around what convenience stores offer in our community.



Healthy Community Store Program



TRUMBULL
NEIGHBORHOOD
PARTNERSHIP